

HITACHI

DASH 3



ZAXIS 850LC-3

- **Engine Rated Power:** 532 SAE net hp (397 kW) @ 1,800 rpm
- **Operating Weight:** 185,876 lb. (84,312 kg)
- **Backhoe Bucket:** 4.57 yd³ (3.49 m³), 54 in. (1,370 mm)

Engine

Type.....	Isuzu AH-6WG1XYSA-03 with turbocharger and air-to-air charge air cooler; certified to EPA Tier-3 emissions
Net Peak Power (ISO9249).....	532 SAE net hp (397 kW) @ 1,800 rpm
Cylinders.....	6
Displacement.....	957 cu. in. (15.681 L)
Maximum Net Torque.....	1,658 lb.-ft. (2250 Nm) @ 1,500 rpm
Cooling Fan (two).....	suction-type, hydraulic-driven, remote-mounted drive
Electrical System.....	24 volt with 50-amp alternator
Batteries (two 12 volt).....	reserve capacity: 280 min.
Off-level capacity.....	70% (35 deg.)

Hydraulic System

Main Pumps	two variable-displacement axial-piston
Maximum Flow.....	2 x 139 gpm (2 x 528 L/min.)
Pilot Pump	one gear
Maximum Flow.....	7.9 gpm (30 L/min.)
Pressure Setting.....	566 psi (3900 kPa)
System Operating Pressure	
Implement Circuits.....	4,627 psi (31 900 kPa)
Travel Circuits.....	4,975 psi (34 300 kPa)
Swing Circuits.....	4,264 psi (29 400 kPa)
Power Boost.....	4,975 psi (34 300 kPa)
Oil Filtration.....	one 10-micron full-flow return filter with by-pass / one pilot oil filter

Cylinders

	Bore	Rod Diameter	Stroke
Boom (2).....	8.5 in. (215 mm)	5.9 in. (150 mm)	72.2 in. (1835 mm)
Arm (1).....	8.9 in. (225 mm)	6.3 in. (160 mm)	87.6 in. (2225 mm)
Bucket (1).....	7.9 in. (200 mm)	5.5 in. (140 mm)	61.2 in. (1555 mm)

Swing Mechanism

Swing Speed.....	0–7.3 rpm
Swing Torque.....	182,223 lb.-ft. (247 250 Nm)

Undercarriage

Carrier Rollers (per side).....	3
Track Rollers (per side).....	9
Shoes, Double-Bar Grouser (per side).....	51
Track Guides.....	front and center
Track Adjustment.....	hydraulic
Travel Speed	
Low.....	0–1.9 mph (0–3.1 km/h)
High.....	0–2.5 mph (0–4.1 km/h)
Drawbar Pull.....	126,193 lb. (57 240 kg)

Ground Pressure Data

Average Ground Pressure	
28-in. (700 mm) Double-Bar Grouser Shoes.....	16.1 psi (111.0 kPa)
32-in. (800 mm) Double-Bar Grouser Shoes.....	14.0 psi (96.5 kPa)
36-in. (900 mm) Double-Bar Grouser Shoes.....	11.8 psi (81.4 kPa)

SAE Operating Weights

With Full Fuel Tank; 175-lb. (79 kg) Operator; 4.57-cu.-yd. (3.49 m³), 54-in. (1370 mm), 7,845-lb. (3558 kg) Bucket; 14-ft. 5-in. (4.4 m) Arm; 29,321-lb. (13 300 kg) Counterweight; and 36-in. (900 mm) Double-Bar Grouser Shoes.....185,876 lb. (84 312 kg)

Capacities (U.S.)

Fuel Tank.....	296 gal. (1120 L)
Cooling System	21.5 gal. (81.4 L)
Engine Lubrication, Including Filter	13.9 gal. (52.6 L)
Hydraulic Tank.....	137.5 gal. (520.5 L)
Hydraulic System	208.7 gal. (790 L)
Propel Gearbox (each).....	16 qt. (15.1 L)
Swing Drive	13 qt. (12.3 L)
Swing Bearing Gear	5.8 gal. (22 L)

Component Weights

Undercarriage

26-in. (650 mm) Double-Bar Grouser Shoes.....	71,320 lb. (32 350 kg)
30-in. (750 mm) Double-Bar Grouser Shoes.....	72,863 lb. (33 050 kg)
36-in. (900 mm) Double-Bar Grouser Shoes.....	74,935 lb. (33 990 kg)
27-ft. 7-in. (8.4 m) One-Piece Boom (with arm cylinder).....	18,056 lb. (8190 kg)
23-ft. 4-in. (7.1 m) Mass-Excavating Boom (with arm cylinder)	16,909 lb. (7670 kg)
32-ft. 10-in. (10.0 m) One-Piece Boom (with arm cylinder)	20,701 lb. (9390 kg)

Arm with Bucket Cylinder and Linkage

12 ft. 2 in. (3.7 m).....	9,546 lb. (4330 kg)
14 ft. 5 in. (4.4 m).....	10,274 lb. (4660 kg)
17 ft. 9 in. (5.4 m).....	10,913 lb. (4950 kg)
23-ft. 4-in. (7.1 m) Mass-Excavating Boom with 9-ft. 8-in. (2.95 m) Arm.....	10,251 lb. (4650 kg)
Boom Lift Cylinders (2) Total Weight	3,748 lb. (1700 kg)
4.57-cu.-yd. (3.49 m ³), 54-in. (1370 mm) Heavy-Duty High-Capacity Bucket	7,844 lb. (3558 kg)
Counterweight, Standard.....	29,321 lb. (13 300 kg)

Lifting Capacities

Boldface italic type indicates hydraulic-limited capacities; lightface type indicates stability-limited capacities, in lb. (kg). Ratings at bucket lift hook; machine equipped with 29,321-lb. (13 300 kg) counterweight; standard gauge; and situated on firm, uniform supporting surface. Total load includes weight of cables, hook, etc. Figures do not exceed 87 percent of hydraulic capacities or 75 percent of weight needed to tip machine. All lift capacities are based on SAE J1097. Lift capacities for the most popular shoe and arm configurations are included. Lift capacities for other configurations are available from your dealer..

Load Point Height	20 ft. (6.1 m)		25 ft. (7.6 m)		30 ft. (9.1 m)		35 ft. (10.7 m)		40 ft. (12.2 m)	
	Over Front	Over Side	Over Front	Over Side	Over Front	Over Side	Over Front	Over Side	Over Front	Over Side
<i>With 27-ft. 7-in. (8.4 m) boom, 14-ft. 5-in. (4.4 m) arm, 3.79-cu.-yd. (2.9 m³) bucket, and 26-in. (650 mm) double-bar grouser shoes</i>										
30 ft. (9.1 m)							18,700 (8482)	18,700 (8482)		
25 ft. (7.6 m)							23,001 (10 433)	23,001 (10 433)		
20 ft. (6.1 m)					28,001 (12 701)	28,001 (12 701)	26,299 (11 929)	26,299 (11 929)	19,701 (8936)	19,701 (8936)
15 ft. (4.6 m)	48,500 (21 999)	48,500 (21 999)	38,400 (17 418)	38,400 (17 418)	32,699 (14 832)	32,699 (14 832)	29,101 (13 200)	26,601 (12 066)	24,101 (10 932)	20,600 (9344)
10 ft. (3.0 m)	60,901 (27 624)	60,901 (27 624)	45,100 (20 457)	44,500 (20 185)	36,700 (16 647)	33,199 (15 059)	31,601 (14 334)	25,501 (11 567)	28,199 (12 791)	19,906 (9029)
5 ft. (1.5 m)			50,799 (23 042)	41,800 (18 960)	40,400 (18 325)	31,500 (14 288)	34,000 (15 422)	24,401 (11 068)	29,701 (13 472)	19,200 (8709)
Ground Line	47,501 (21 546)	47,501 (21 546)	54,500 (24 721)	39,899 (18 098)	43,100 (19 550)	30,199 (13 698)	35,801 (16 239)	23,499 (10 659)	29,899 (13 562)	18,700 (8482)
-5 ft. (-1.5 m)	61,701 (27 987)	55,400 (25 129)	55,799 (25 310)	38,901 (17 645)	44,500 (20 185)	29,299 (13 290)	36,599 (16 601)	22,899 (10 387)	29,500 (13 381)	18,301 (8301)
-10 ft. (-3.0 m)	69,900 (31 706)	55,499 (25 174)	55,100 (24 993)	38,601 (17 509)	44,300 (20 094)	28,900 (13 109)	36,299 (16 465)	22,600 (10 251)	25,100 (11 385)	18,199 (8255)
-15 ft. (-4.6 m)	65,001 (29 484)	56,000 (25 401)	52,100 (23 632)	38,799 (17 599)	42,201 (19 142)	29,000 (13 154)	34,101 (15 468)	22,701 (10 297)		
-20 ft. (-6.1 m)	57,100 (25 900)	57,001 (25 855)	46,299 (21 001)	39,500 (17 917)	37,099 (16 828)	29,599 (13 426)				
-25 ft. (-7.6 m)	44,600 (20 230)	44,600 (20 230)	35,699 (16 193)	35,699 (16 193)						
<i>With 23-ft. 4-in. (7.1 m) ME boom, 9-ft. 8-in. (2.95 m) ME arm, 5.89-cu.-yd. (4.5 m³) bucket, and 26-in. (650 mm) double-bar grouser shoes</i>										
25 ft. (9.1 m)			34,800 (15 785)	34,800 (15 785)						
25 ft. (7.6 m)			36,500 (16 556)	36,500 (16 556)	24,701 (11 204)	24,701 (11 204)				
20 ft. (6.1 m)			39,099 (17 735)	39,099 (17 735)	36,101 (16 375)	34,800 (15 785)				
15 ft. (4.6 m)	54,500 (24 721)	54,500 (24 721)	43,901 (19 913)	43,901 (19 913)	38,200 (17 327)	33,799 (15 331)				
10 ft. (3.0 m)			49,600 (22 498)	44,200 (20 049)	41,101 (18 643)	32,399 (14 696)	28,700 (13 018)	24,200 (10 977)		
5 ft. (1.5 m)			54,201 (24 585)	41,901 (19 006)	43,601 (19 777)	30,999 (14 061)	32,900 (14 923)	23,501 (10 660)		
Ground Line			56,500 (25 628)	40,400 (18 325)	45,001 (20 412)	30,001 (13 608)				
-5 ft. (-1.5 m)	71,600 (32 477)	57,100 (25 900)	55,799 (25 310)	39,599 (17 962)	44,200 (20 049)	29,401 (13 336)				
-10 ft. (-3.0 m)	65,400 (29 665)	57,199 (25 945)	51,701 (23 451)	39,500 (17 917)	39,800 (18 053)	29,401 (13 336)				
-15 ft. (-4.6 m)	54,300 (24 630)	54,300 (24 630)	42,099 (19 096)	40,199 (18 234)						

ZAXIS 850LC-3 SPECIFICATIONS

Lifting Capacities

Boldface italic type indicates hydraulic-limited capacities; lightface type indicates stability-limited capacities, in lb. (kg). Ratings at bucket lift hook; machine equipped with 29,321-lb. (13 300 kg) counterweight; standard gauge; and situated on firm, uniform supporting surface. Total load includes weight of cables, hook, etc. Figures do not exceed 87 percent of hydraulic capacities or 75 percent of weight needed to tip machine. All lift capacities are based on SAE J1097. Lift capacities for the most popular shoe and arm configurations are included. Lift capacities for other configurations are available from your dealer..

Load Point Height	20 ft. (6.1 m)		25 ft. (7.6 m)		30 ft. (9.1 m)		35 ft. (10.7 m)		40 ft. (12.2 m)	
	Over Front	Over Side	Over Front	Over Side	Over Front	Over Side	Over Front	Over Side	Over Front	Over Side
<i>With 27-ft. 7-in. (8.4 m) boom, 14-ft. 5-in. (4.4 m) arm, 3.79-cu.-yd. (2.9 m³) bucket, and 30-in. (750 mm) double-bar grouser shoes</i>										
30 ft. (9.1 m)							18,700 (8482)	18,700 (8482)		
25 ft. (7.6 m)							23,001 (10 433)	23,001 (10 433)		
20 ft. (6.1 m)					28,001 (12 701)	28,001 (12 701)	26,299 (11 929)	26,299 (11 929)	19,701 (8936)	19,701 (8936)
15 ft. (4.6 m)	48,500 (21 999)	48,500 (21 999)	38,400 (17 418)	38,400 (17 418)	32,699 (14 832)	32,699 (14 832)	29,101 (13 200)	26,901 (12 202)	24,101 (10 932)	20,801 (9435)
10 ft. (3.0 m)	60,901 (27 624)	60,901 (27 624)	45,100 (20 457)	44,800 (20 321)	36,700 (16 647)	33,499 (15 195)	31,601 (14 334)	25,699 (11 657)	28,199 (12 791)	20,100 (9117)
5 ft. (1.5 m)			50,799 (23 042)	42,099 (19 096)	40,400 (18 325)	31,799 (14 424)	34,000 (15 422)	24,701 (11 204)	29,701 (13 472)	19,401 (8800)
Ground Line	47,501 (21 546)	47,501 (21 546)	54,500 (24 721)	40,301 (18 280)	43,100 (19 550)	30,501 (13 835)	35,801 (16 239)	23,801 (10 796)	30,199 (13 698)	18,900 (8573)
-5 ft. (-1.5 m)	61,701 (27 987)	56,000 (25 401)	55,799 (25 310)	39,300 (17 826)	44,500 (20 185)	29,599 (13 426)	36,800 (16 692)	23,100 (10 478)	29,800 (13 517)	18,499 (8391)
-10 ft. (-3.0 m)	69,900 (31 706)	56,000 (25 401)	55,100 (24 933)	39,000 (17 690)	44,300 (20 094)	29,200 (13 245)	36,401 (16 511)	22,899 (10 387)	25,100 (11 395)	18,400 (8346)
-15 ft. (-4.6 m)	65,001 (29 484)	56,500 (25 628)	52,100 (23 632)	39,200 (17 781)	42,201 (19 142)	29,299 (13 290)	34,101 (15 468)	23,001 (10 433)		
-20 ft. (-6.1 m)	57,100 (25 900)	57,100 (25 900)	46,299 (21 001)	39,899 (18 098)	37,099 (16 828)	29,899 (13 562)				
-25 ft. (-7.6 m)	44,600 (20 230)	44,600 (20 230)	35,699 (16 193)	35,699 (16 193)						
<i>With 27-ft. 7-in. (8.4 m) boom, 12-ft. 2-in. (3.7 m) arm, 4.58-cu.-yd. (3.5 m³) bucket, and 36-in. (900 mm) double-bar grouser shoes</i>										
25 ft. (7.6 m)					28,900 (13 109)	28,900 (13 109)	24,401 (11 068)	24,401 (11 068)		
20 ft. (6.1 m)					31,400 (14 243)	31,400 (14 243)	28,900 (13 109)	27,500 (12 474)		
15 ft. (4.6 m)	54,701 (24 812)	54,701 (24 812)	41,700 (18 915)	41,700 (18 915)	34,899 (15 830)	34,899 (15 830)	30,900 (14 016)	26,601 (12 066)	21,499 (9752)	20,501 (9299)
10 ft. (3.0 m)			48,100 (21 818)	44,200 (20 049)	38,700 (17 554)	33,199 (15 059)	33,100 (15 014)	25,600 (11 612)	27,500 (12 474)	20,000 (9072)
5 ft. (1.5 m)			53,101 (24 086)	41,901 (19 006)	42,000 (19 051)	31,700 (14 379)	35,100 (15 921)	24,599 (11 158)	30,600 (13 880)	19,401 (8800)
Ground Line			55,700 (25 265)	40,400 (18 325)	44,099 (20 003)	30,600 (13 880)	36,500 (16 556)	23,900 (10 841)	30,400 (13 789)	18,999 (8618)
-5 ft. (-1.5 m)	67,700 (30 708)	57,001 (25 855)	56,000 (25 401)	39,800 (18 053)	44,800 (20 321)	29,899 (13 562)	36,901 (16 738)	23,400 (10 614)		
-10 ft. (-3.0 m)	67,199 (30 481)	57,300 (25 991)	54,099 (24 539)	39,701 (18 008)	43,799 (19 867)	29,701 (13 472)	35,699 (16 193)	23,301 (10 569)		
-15 ft. (-4.6 m)	61,099 (27 714)	57,999 (26 308)	49,899 (22 634)	40,100 (18 189)	40,499 (18 370)	30,001 (13 608)				
-20 ft. (-6.1 m)	51,599 (23 405)	51,599 (23 405)	42,300 (19 187)	40,704 (18 463)	32,900 (14 923)	30,999 (14 061)				
<i>With 27-ft. 7-in. (8.4 m) boom, 14-ft. 5-in. (4.4 m) arm, 3.79-cu.-yd. (2.9 m³) bucket, and 36-in. (900 mm) double-bar grouser shoes</i>										
30 ft. (9.1 m)							18,700 (8482)	18,700 (8482)		
25 ft. (7.6 m)							23,001 (10 433)	23,001 (10 433)		
20 ft. (6.1 m)					28,001 (12 701)	28,001 (12 701)	26,299 (11 929)	26,299 (11 929)	19,701 (8936)	19,701 (8936)
15 ft. (4.6 m)	48,500 (21 999)	48,500 (21 999)	38,400 (17 418)	38,400 (17 418)	32,699 (14 832)	32,699 (14 832)	29,101 (13 200)	27,201 (12 338)	24,101 (10 932)	21,100 (9571)
10 ft. (3.0 m)	60,901 (27 624)	60,901 (27 624)	45,100 (20 457)	45,100 (20 457)	36,700 (16 647)	33,900 (15 377)	31,601 (14 334)	26,101 (11 839)	28,202 (12 792)	20,399 (9253)
5 ft. (1.5 m)			50,799 (23 042)	42,600 (19 323)	40,400 (18 325)	32,201 (14 606)	34,000 (15 422)	25,000 (11 340)	29,701 (13 472)	19,701 (8936)
Ground Line	47,501 (21 546)	47,501 (21 546)	54,500 (24 721)	40,801 (18 507)	43,100 (19 550)	30,900 (14 016)	35,801 (16 239)	24,101 (10 932)	30,600 (13 880)	19,101 (8664)
-5 ft. (-1.5 m)	61,701 (27 987)	56,599 (25 673)	55,799 (25 310)	39,800 (18 053)	44,500 (20 185)	30,001 (13 608)	36,800 (16 692)	23,499 (10 659)	30,199 (13 698)	18,801 (8528)
-10 ft. (-3.0 m)	69,900 (31 706)	56,701 (25 719)	55,100 (24 933)	39,500 (17 917)	44,300 (20 094)	29,599 (13 426)	36,401 (16 511)	23,199 (10 523)	25,100 (11 395)	18,700 (8482)
-15 ft. (-4.6 m)	65,001 (29 484)	57,199 (25 945)	52,100 (23 632)	39,599 (17 962)	42,201 (19 142)	29,701 (13 472)	34,101 (15 468)	23,301 (10 569)		
-20 ft. (-6.1 m)	57,100 (25 900)	57,100 (25 900)	46,299 (21 001)	40,301 (18 280)	37,099 (16 828)	30,300 (13 744)				
-25 ft. (-7.6 m)	44,600 (20 230)	44,600 (20 230)	35,699 (16 193)	35,699 (16 193)						
<i>With 27-ft. 7-in. (8.4 m) boom, 17-ft. 9-in. (5.4 m) arm, 3.01-cu.-yd. (2.3 m³) bucket, and 36-in. (900 mm) double-bar grouser shoes</i>										
30 ft. (9.1 m)									11,199 (5080)	11,199 (5080)
25 ft. (7.6 m)									19,299 (8754)	19,299 (8754)
20 ft. (6.1 m)									21,200 (9616)	21,200 (9616)
15 ft. (4.6 m)					26,200 (11 884)	26,200 (11 884)	24,701 (11 204)	24,701 (11 204)	18,999 (8618)	18,999 (8618)
10 ft. (3.0 m)	52,300 (23 723)	52,300 (23 723)	40,301 (18 280)	40,301 (18 280)	33,601 (15 241)	33,601 (15 241)	29,299 (13 290)	26,500 (12 020)	25,100 (11 385)	20,600 (9344)
5 ft. (1.5 m)	62,699 (28 440)	61,599 (27 941)	46,701 (21 183)	43,700 (19 822)	37,600 (17 055)	32,699 (14 832)	32,000 (14 515)	25,300 (11 476)	28,100 (12 746)	19,800 (8981)
Ground Line	65,700 (29 801)	58,101 (26 354)	51,500 (23 360)	41,299 (18 733)	40,999 (18 597)	31,101 (14 107)	34,200 (15 513)	24,200 (10 977)	29,599 (13 426)	19,101 (8664)
-5 ft. (-1.5 m)	65,400 (29 665)	56,401 (25 583)	54,399 (24 675)	39,800 (18 053)	43,200 (19 595)	30,001 (13 608)	35,801 (16 239)	23,400 (10 614)	30,100 (13 653)	18,600 (8437)
-10 ft. (-3.0 m)	71,600 (32 477)	55,700 (25 265)	55,100 (24 933)	39,000 (17 690)	44,099 (20 003)	29,299 (13 290)	36,299 (16 465)	22,899 (10 387)	29,701 (13 472)	18,301 (8301)
-15 ft. (-4.6 m)	68,700 (31 162)	55,700 (25 265)	53,799 (24 403)	38,799 (17 599)	43,200 (19 595)	29,101 (13 200)	35,300 (16 012)	22,701 (10 297)	25,000 (11 340)	18,400 (8346)
-20 ft. (-6.1 m)	63,101 (28 622)	56,401 (25 583)	50,001 (22 680)	39,200 (17 781)	40,199 (18 234)	29,299 (13 290)	32,000 (14 515)	23,100 (10 478)		
-25 ft. (-7.6 m)	53,799 (24 403)	53,799 (24 403)	42,801 (19 414)	40,100 (18 189)	33,301 (15 105)	30,199 (13 698)				
<i>With 23-ft. 4-in. (7.1 m) ME boom, 9-ft. 8-in. (2.95 m) ME arm, 5.89-cu.-yd. (4.5 m³) bucket, and 36-in. (900 mm) double-bar grouser shoes</i>										
30 ft. (9.1 m)			34,800 (15 785)	34,800 (15 785)						
25 ft. (7.6 m)			36,500 (16 556)	36,500 (16 556)	24,701 (11 204)	24,701 (11 204)				
20 ft. (6.1 m)			39,099 (17 735)	39,099 (17 735)	36,101 (16 375)	35,501 (16 103)				
15 ft. (4.6 m)	54,500 (24 721)	54,500 (24 721)	43,901 (19 913)	43,901 (19 913)	38,200 (17 327)	34,401 (15 604)				
10 ft. (3.0 m)			49,600 (22 498)	45,100 (20 457)	41,101 (18 643)	33,100 (15 014)	28,700 (13 018)	24,701 (11 204)		
5 ft. (1.5 m)			54,201 (24 585)	42,801 (19 414)	43,601 (19 777)	31,700 (14 379)	32,900 (14 923)	24,101 (10 932)		
Ground Line			56,500 (25 628)	41,200 (18 688)	45,001 (20 412)	30,699 (13 925)				
-5 ft. (-1.5 m)	71,600 (32 477)	58,299 (26 444)	55,799 (25 310)	40,400 (18 325)	44,200 (20 049)	30,100 (13 653)				
-10 ft. (-3.0 m)	65,400 (29 665)	58,400 (26 490)	51,701 (23 451)	40,301 (18 280)	39,800 (18 053)	30,100 (13 653)				
-15 ft. (-4.6 m)	54,300 (24 630)	54,300 (24 630)	42,099 (19 096)	41,101 (18 643)						

Lifting Capacities

Boldface italic type indicates hydraulic-limited capacities; lightface type indicates stability-limited capacities, in lb. (kg). Ratings at bucket lift hook; machine equipped with 29,321-lb. (13 300 kg) counterweight; standard gauge; and situated on firm, uniform supporting surface. Total load includes weight of cables, hook, etc. Figures do not exceed 87 percent of hydraulic capacities or 75 percent of weight needed to tip machine. All lift capacities are based on SAE J1097. Lift capacities for the most popular shoe and arm configurations are included. Lift capacities for other configurations are available from your dealer..

Load Point Height	20 ft. (6.1 m)		25 ft. (7.6 m)		30 ft. (9.1 m)		35 ft. (10.7 m)		40 ft. (12.2 m)	
	Over Front	Over Side	Over Front	Over Side	Over Front	Over Side	Over Front	Over Side	Over Front	Over Side
<i>With 32-ft. 10-in. (10.0 m) boom, 14-ft. 5-in. (4.4 m) arm, 2.63-cu.-yd. (2.0 m³) bucket, 36-in. (900 mm) double-bar grouser shoes, and standard counterweight</i>										
35 ft. (10.7 m)									14,783 (6705)	14,783 (6705)
30 ft. (9.1 m)									19,967 (9057)	19,967 (9057)
25 ft. (7.6 m)							21,642 (9817)	21,642 (9817)	20,526 (9310)	20,526 (9310)
20 ft. (6.1 m)					26,871 (12 188)	26,871 (12 188)	23,740 (10 768)	23,740 (10 768)	21,746 (9864)	21,484 (9745)
15 ft. (4.6 m)			38,834 (17 615)	38,834 (17 615)	30,886 (14 010)	30,886 (14 010)	26,270 (11 916)	26,270 (11 916)	23,344 (10 589)	20,532 (9313)
10 ft. (3.0 m)					34,916 (15 838)	31,367 (14 228)	28,902 (13 110)	24,612 (11 164)	25,081 (11 377)	19,539 (8863)
5 ft. (1.5 m)					38,304 (17 374)	29,459 (13 362)	31,287 (14 192)	23,281 (10 560)	26,726 (12 123)	18,623 (8447)
Ground Line			42,442 (19 251)	36,754 (16 671)	40,626 (18 428)	28,150 (12 769)	33,139 (15 032)	22,252 (10 093)	28,069 (12 732)	17,875 (8108)
-5 ft. (-1.5 m)			52,445 (23 789)	36,263 (16 449)	41,789 (18 955)	27,401 (12 429)	34,273 (15 546)	21,572 (9785)	28,789 (13 058)	17,353 (7871)
-10 ft. (-3.0 m)	34,530 (15 663)	34,530 (15 663)	51,577 (23 395)	36,226 (16 432)	41,841 (18 979)	27,102 (12 293)	34,567 (15 679)	21,233 (9631)	28,509 (12 931)	17,091 (7752)
-15 ft. (-4.6 m)	58,098 (26 353)	53,373 (24 210)	49,585 (22 491)	36,530 (16 570)	40,768 (18 492)	27,175 (12 326)	33,864 (15 360)	21,228 (9629)	28,332 (12 851)	17,130 (7770)
-20 ft. (-6.1 m)	55,718 (25 273)	54,281 (24 621)	46,257 (20 982)	37,169 (16 860)	38,361 (17 400)	27,605 (12 521)	31,815 (14 431)	21,583 (9790)	25,844 (11 723)	17,595 (7981)
-25 ft. (-7.6 m)	49,005 (22 228)	49,005 (22 228)	41,033 (18 612)	38,219 (17 336)	34,003 (15 424)	28,469 (12 913)	27,367 (12 413)	22,464 (10 189)		
-30 ft. (-9.1 m)	38,894 (17 642)	38,894 (17 642)	32,532 (14 756)	32,532 (14 756)	25,583 (11 604)	25,583 (11 604)				
<i>With 32-ft. 10-in. (10.0 m) boom, 17-ft. 9-in. (5.4 m) arm, 2.48-cu.-yd. (1.9 m³) bucket, 36-in. (900 mm) double-bar grouser shoes, and standard counterweight</i>										
40 ft. (12.2 m)									12,285 (5572)	12,285 (5572)
35 ft. (10.7 m)									17,439 (7910)	17,439 (7910)
30 ft. (9.1 m)									17,933 (8134)	17,933 (8134)
25 ft. (7.6 m)									18,772 (8515)	18,772 (8515)
20 ft. (6.1 m)							21,806 (9891)	21,806 (9891)	20,137 (9134)	20,137 (9134)
15 ft. (4.6 m)			34,351 (15 581)	34,351 (15 581)	28,196 (12 789)	28,196 (12 789)	24,375 (11 056)	24,375 (11 056)	21,843 (9908)	21,177 (9606)
10 ft. (3.0 m)			40,832 (18 521)	40,832 (18 521)	32,282 (14 643)	32,282 (14 643)	27,103 (12 294)	25,470 (11 553)	23,701 (10 751)	20,112 (9123)
5 ft. (1.5 m)			46,234 (20 971)	39,756 (18 033)	35,992 (16 326)	30,524 (13 845)	29,691 (13 468)	23,978 (10 876)	25,517 (11 574)	19,089 (8659)
Ground Line			49,828 (22 602)	37,571 (17 042)	38,897 (17 643)	28,829 (13 077)	31,871 (14 456)	22,739 (10 314)	27,102 (12 293)	18,206 (8258)
-5 ft. (-1.5 m)			51,654 (23 430)	36,375 (16 499)	40,795 (18 504)	27,697 (12 563)	33,448 (15 172)	21,830 (9902)	28,288 (12 831)	17,528 (7951)
-10 ft. (-3.0 m)	33,830 (15 345)	33,830 (15 345)	52,023 (23 597)	35,875 (16 273)	41,644 (18 889)	27,073 (12 280)	34,286 (15 552)	21,269 (9647)	28,535 (12 943)	17,097 (7755)
-15 ft. (-4.6 m)	49,052 (22 250)	49,052 (22 250)	51,121 (23 188)	35,873 (16 272)	41,418 (18 787)	26,881 (12 193)	34,255 (15 057)	21,051 (9549)	28,370 (12 868)	16,943 (7685)
-20 ft. (-6.1 m)	60,801 (27 579)	52,560 (23 841)	48,903 (22 182)	36,286 (16 459)	39,992 (18 140)	27,079 (12 283)	33,128 (15 027)	21,180 (9607)	27,529 (12 487)	17,118 (7765)
-25 ft. (-7.6 m)	55,400 (25 129)	53,814 (24 410)	45,056 (20 437)	37,115 (16 835)	37,007 (16 786)	27,684 (12 557)	30,385 (13 782)	21,719 (9852)	24,006 (10 889)	17,818 (8082)
-30 ft. (-9.1 m)	47,393 (21 497)	47,393 (21 497)	38,799 (17 599)	38,469 (17 449)	31,509 (14 292)	28,831 (13 078)	24,224 (10 988)	22,967 (10 418)		
<i>With 32-ft. 10-in. (10.0 m) boom, 14-ft. 5-in. (4.4 m) arm, 2.63-cu.-yd. (2.0 m³) bucket, 40-in. (1020 mm) double-bar grouser shoes, and standard counterweight</i>										
35 ft. (10.7 m)									14,783 (6705)	14,783 (6705)
30 ft. (9.1 m)									19,967 (9057)	19,967 (9057)
25 ft. (7.6 m)							21,642 (9817)	21,642 (9817)	20,526 (9310)	20,526 (9310)
20 ft. (6.1 m)					26,871 (12 188)	26,871 (12 188)	23,740 (10 768)	23,740 (10 768)	21,746 (9864)	21,746 (9864)
15 ft. (4.6 m)			38,834 (17 615)	38,834 (17 615)	30,886 (14 010)	30,886 (14 010)	26,270 (11 916)	26,270 (11 916)	23,344 (10 589)	20,775 (9423)
10 ft. (3.0 m)					34,916 (15 838)	31,711 (14 384)	28,902 (13 110)	24,896 (11 293)	25,081 (11 377)	19,782 (8973)
5 ft. (1.5 m)					38,304 (17 374)	29,803 (13 518)	31,287 (14 192)	23,565 (10 689)	26,726 (12 123)	18,865 (8557)
Ground Line			42,442 (19 251)	37,189 (16 869)	40,626 (18 428)	28,494 (12 925)	33,139 (15 032)	22,536 (10 222)	28,069 (12 732)	18,117 (8218)
-5 ft. (-1.5 m)			52,445 (23 789)	36,697 (16 645)	41,789 (18 955)	27,745 (12 585)	34,273 (15 546)	21,856 (9914)	28,926 (13 121)	17,595 (7981)
-10 ft. (-3.0 m)	34,530 (15 663)	34,530 (15 663)	51,577 (23 395)	36,661 (16 629)	41,841 (18 979)	27,446 (12 449)	34,567 (15 679)	21,518 (9760)	28,858 (13 090)	17,333 (7862)
-15 ft. (-4.6 m)	58,098 (26 353)	53,965 (24 478)	49,585 (22 491)	36,964 (16 767)	40,768 (18 492)	27,519 (12 482)	33,864 (15 360)	21,512 (9758)	28,332 (12 851)	17,372 (7880)
-20 ft. (-6.1 m)	55,718 (25 273)	54,872 (24 890)	46,257 (20 982)	37,603 (17 056)	38,361 (17 400)	27,949 (12 677)	31,815 (14 431)	21,867 (9919)	25,844 (11 723)	17,838 (8091)
-25 ft. (-7.6 m)	49,005 (22 228)	49,005 (22 228)	41,033 (18 612)	38,654 (17 533)	34,003 (15 424)	28,813 (13 069)	27,367 (12 413)	22,748 (10 318)		
-30 ft. (-9.1 m)	38,894 (17 642)	38,894 (17 642)	32,532 (14 756)	32,532 (14 756)	25,583 (11 604)	25,583 (11 604)				

Buckets

A full line of buckets is offered to meet a wide variety of applications. Digging forces are with power boost. The buckets have an adjustable bushing for side clearance, with the exception of the ditching bucket. Tooth selection includes either the John Deere Fanggs®, Standard, Tiger, Twin Tiger, Abrasion panel, or Flare tooth, or the ESCO (Vertalok) Standard, Tiger, Twin Tiger, or Flare tooth. Replaceable cutting edges are available through Hitachi parts. Optional side cutters add 6 inches (150 mm) to bucket widths. Capacities are SAE heaped ratings with side cutters.

Type Bucket	Bucket Width		Bucket Capacity*		Weight		Bucket Dig Force		Arm Dig Force 12 ft. 2 in. (3.7 m)		Arm Dig Force 14 ft. 5 in. (4.4 m)		Arm Dig Force 17 ft. 9 in. (5.4 m)		ME Arm Dig Force 9 ft. 8 in. (2.95 m)		Bucket Tip Radius		No. Teeth
	in.	mm	cu. yd.	m³	lb.	kg	lb.	kN	lb.	kN	lb.	kN	lb.	kN	lb.	kN	in.	mm	
Heavy-Duty High Capacity	36	914	2.7	2.09	6,100	2767	80,699	359	70,808	315	62,272	277					95.53	2426	3
	42	1067	3.3	2.55	6,552	2972	80,699	359	70,808	315	61,727	275					95.53	2426	4
	48	1219	3.9	3.02	7,004	3177	80,699	359	70,808	315	62,272	275					95.53	2426	4
	54	1372	4.6	3.49	7,844	3558	80,699	359	70,808	315	62,272	277					95.53	2426	5
	60	1524	5.2	3.98	7,875	3572	80,699	359	70,808	315	62,272	277					95.53	2426	5
	72	1829	6.5	4.96	8,346	3786	80,699	359	70,808	315	61,727	275					95.53	2426	6
	80	2032	7.4	5.63	9,963	4519	80,699	359	70,808	315	61,727	275					95.53	2426	6
High-Capacity Dirt	90	2286	7.6	5.81	9,471	4296	92,388	411						84,970	378		90.66	2303	7
Heavy Duty	36	914	2.0	1.51	5,534	2510	64,964	289					53,724	239			83.19	2113	3
	42	1067	2.4	1.86	6,087	2761	64,964	289					53,724	239			83.19	2113	4
	48	1219	2.9	2.22	6,471	2935	64,964	289					53,724	239			83.19	2113	4
	54	1372	3.4	2.58	6,814	3091	64,964	289					53,724	239			83.19	2113	5
	60	1524	3.9	2.95	7,125	3232	64,964	289					53,724	239			83.19	2113	5
Truck Loading	84	2134	5.5	4.21	7,242	3285	92,653	412	73,959	329	64,181	285					85.22	2165	6
	92	2337	6.0	4.63	7,932	3598	92,653	412	73,959	329	64,181	285					85.22	2165	8

*All capacities are SAE heaped ratings and with side cutters.

Bucket Selection Guide*

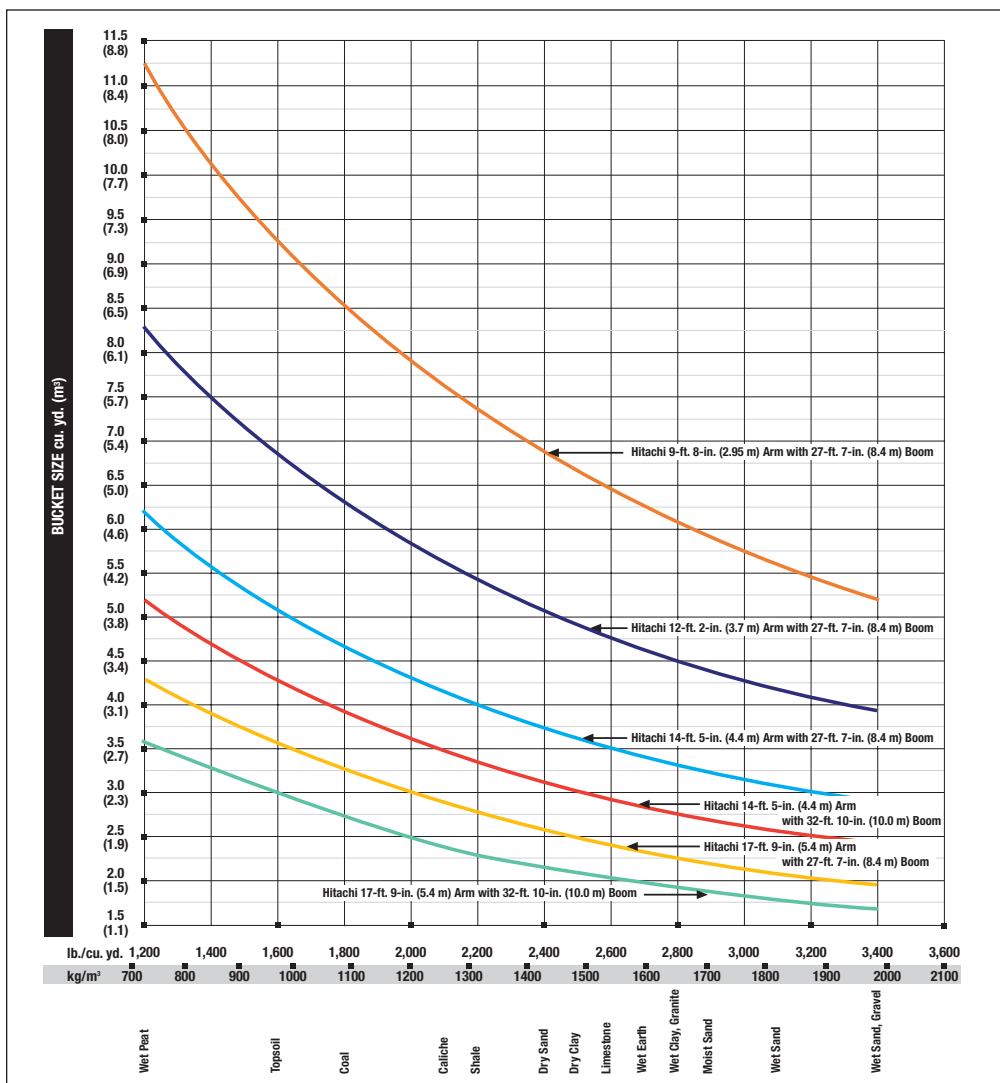

*Contact your Hitachi dealer for optimum bucket and attachment selections. These recommendations are for general conditions and average use. Does not include optional equipment such as thumbs or couplers. Larger buckets may be possible when using light materials, for flat and level operations, less compacted materials, and volume loading applications such as mass excavation applications in ideal conditions. Smaller buckets are recommended for adverse conditions such as off-level applications, rocks, and uneven surfaces. Bucket capacity indicated is SAE heaped.

Operating Information

	27-ft. 7-in. (8.4 m) Boom with 12-ft. 2-in. (3.7 m) Arm	27-ft. 7-in. (8.4 m) Boom with 14-ft. 5-in. (4.4 m) Arm	27-ft. 7-in. (8.4 m) Boom with 17-ft. 9-in. (5.4 m) Arm	23-ft. 4-in. (7.1 m) Mass- Excavating Boom with 9-ft. 8-in. (2.95 m) Arm	32-ft. 10-in. (10.0 m) Boom with 14-ft. 5-in. (4.4 m) Arm	32-ft. 10-in. (10.0 m) Boom with 17-ft. 9-in. (5.4 m) Arm
Arm Force*	70,808 lb. (315 kN)	62,272 lb. (277 kN)	53,724 lb. (239 kN)	84,970 lb. (378 kN)	61,373 lb. (273 kN)	53,729 lb. (239 kN)
Bucket Digging Force*	80,699 lb. (359 kN)	81,381 lb. (362 kN)	64,964 lb. (289 kN)	92,388 lb. (411 kN)	80,706 lb. (359 kN)	64,970 lb. (289 kN)
Lifting Capacity Over Front at Ground Level 25-ft. (7.6 m) Reach*						
	55,702 lb. (25 266 kg)	54,500 lb. (24 721 kg)	51,500 lb. (23 360 kg)	56,500 lb. (25 628 kg)	42,442 lb. (19 251 kg)	49,828 lb. (22 602 kg)
A Maximum Reach	46 ft. 3 in. (14.10 m)	48 ft. 11 in. (14.91 m)	52 ft. 2 in. (15.91 m)	40 ft. 6 in. (12.34 m)	54 ft. 4 in. (16.55 m)	57 ft. 7 in. (17.56 m)
A' Maximum Reach at Ground Level	45 ft. 4 in. (13.82 m)	48 ft. (14.64 m)	51 ft. 5 in. (15.67 m)	39 ft. 5 in. (12.02 m)	53 ft. 7 in. (16.32 m)	56 ft. 11 in. (17.34 m)
B Maximum Digging Depth	29 ft. 1 in. (8.87 m)	31 ft. 5 in. (9.57 m)	34 ft. 8 in. (10.57 m)	23 ft. 5 in. (7.14 m)	36 ft. 7 in. (11.16 m)	39 ft. 11 in. (12.16 m)
B' Maximum Digging Depth @ 8-ft. (2.44 m) Flat Bottom	28 ft. 8 in. (8.74 m)	31 ft. (9.46 m)	34 ft. 4 in. (10.46 m)	23 ft. (7.0 m)	36 ft. 3 in. (11.04 m)	39 ft. 7 in. (12.06 m)
C Maximum Cutting Height	42 ft. 9 in. (13.03 m)	45 ft. 4 in. (13.82 m)	47 ft. 8 in. (14.53 m)	39 ft. 5 in. (12.01 m)	48 ft. 1 in. (14.66 m)	50 ft. 4 in. (15.34 m)
D Maximum Dumping Height	29 ft. 9 in. (9.08 m)	31 ft. 11 in. (9.73 m)	34 ft. 2 in. (10.41 m)	26 ft. 8 in. (8.13 m)	35 ft. 6 in. (10.81 m)	36 ft. 11 in. (11.26 m)
E Minimum Swing Radius	19 ft. 6 in. (5.95 m)	19 ft. 6 in. (5.94 m)	19 ft. 6 in. (5.94 m)	17 ft. 1 in. (5.21 m)	24 ft. 1 in. (7.35 m)	24 ft. (7.32 m)
F Maximum Vertical Wall	23 ft. 6 in. (7.17 m)	27 ft. 10 in. (8.48 m)	32 ft. (9.75 m)	13 ft. 5 in. (4.1 m)	32 ft. 5 in. (9.87 m)	37 ft. 2 in. (11.34 m)
G Tail Swing Radius	15 ft. 1 in. (4.6 m)	15 ft. 1 in. (4.6 m)	15 ft. 1 in. (4.6 m)	15 ft. 1 in. (4.6 m)	15 ft. 1 in. (4.6 m)	15 ft. 1 in. (4.6 m)

*With power boost.

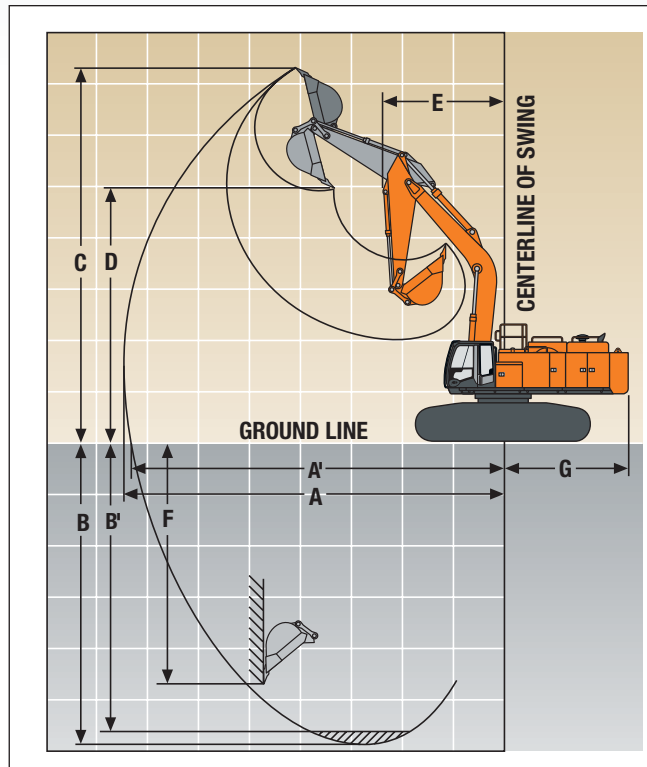

Dimensions

	<i>Arm Length</i> 12 ft. 2 in. (3.7 m)	<i>Arm Length</i> 14 ft. 5 in. (4.4 m)	<i>Arm Length</i> 17 ft. 9 in. (5.4 m)	<i>Arm Length</i> 23-ft. 4-in. (7.1 m) <i>Mass-Excavating</i> <i>Boom w/9-ft. 8-in.</i> <i>(2.95 m) Arm</i>
A Overall Height.....	15 ft. (4.57 m)	15 ft. 9 in. (4.81 m)	18 ft. 6 in. (5.64 m)	17 ft. 1 in. (5.21 m)
B Overall Length.....	48 ft. 6 in. (14.78 m)	48 ft. 8 in. (14.83 m)	47 ft. 11 in. (14.61 m)	44 ft. 4 in. (13.51 m)
C Rear-End Length/Swing Radius.....	14 ft. 10 in. (4.52 m)	14 ft. 10 in. (4.52 m)	14 ft. 10 in. (4.52 m)	14 ft. 10 in. (4.52 m)
D Distance Between Idler/Sprocket Centerline.....	16 ft. 9 in. (5.11 m)	16 ft. 9 in. (5.11 m)	16 ft. 9 in. (5.11 m)	16 ft. 9 in. (5.11 m)
E Undercarriage Length.....	20 ft. 10 in. (6.35 m)	20 ft. 10 in. (6.35 m)	20 ft. 10 in. (6.35 m)	20 ft. 10 in. (6.35 m)
F Counterweight Clearance.....	5 ft. 6 in. (1.68 m)	5 ft. 6 in. (1.68 m)	5 ft. 6 in. (1.68 m)	5 ft. 6 in. (1.68 m)
G Upperstructure Width.....	13 ft. 6 in. (4.11 m)	13 ft. 6 in. (4.11 m)	13 ft. 6 in. (4.11 m)	13 ft. 6 in. (4.11 m)
H Cab Height.....	11 ft. 11 in. (3.63 m)	11 ft. 11 in. (3.63 m)	11 ft. 11 in. (3.63 m)	11 ft. 11 in. (3.63 m)
I Track Width (double-bar grouser shoes).....	26 in. (650 mm) / 30 in. (750 mm) / 36 in. (900 mm)	26 in. (650 mm) / 30 in. (750 mm) / 36 in. (900 mm)	26 in. (650 mm) / 30 in. (750 mm) / 36 in. (900 mm)	26 in. (650 mm) / 30 in. (750 mm) / 36 in. (900 mm)
J 36-in. (900 mm) Double-Bar Grouser Shoes Operating Position.....	11 ft. 4 in. (3.45 m)	11 ft. 4 in. (3.45 m)	11 ft. 4 in. (3.45 m)	11 ft. 4 in. (3.45 m)
Transport Position.....	9 ft. 3 in. (2.82 m)	9 ft. 3 in. (2.82 m)	9 ft. 3 in. (2.82 m)	9 ft. 3 in. (2.82 m)
K Ground Clearance.....	35 in. (890 mm)	35 in. (890 mm)	35 in. (890 mm)	35 in. (890 mm)
L 36-in. (900 mm) Double-Bar Grouser Shoes Operating Position.....	14 ft. 3 in. (4.34 m)	14 ft. 3 in. (4.34 m)	14 ft. 3 in. (4.34 m)	14 ft. 3 in. (4.34 m)
Transport Position.....	12 ft. 3 in. (3.73 m)	12 ft. 3 in. (3.73 m)	12 ft. 3 in. (3.73 m)	12 ft. 3 in. (3.73 m)

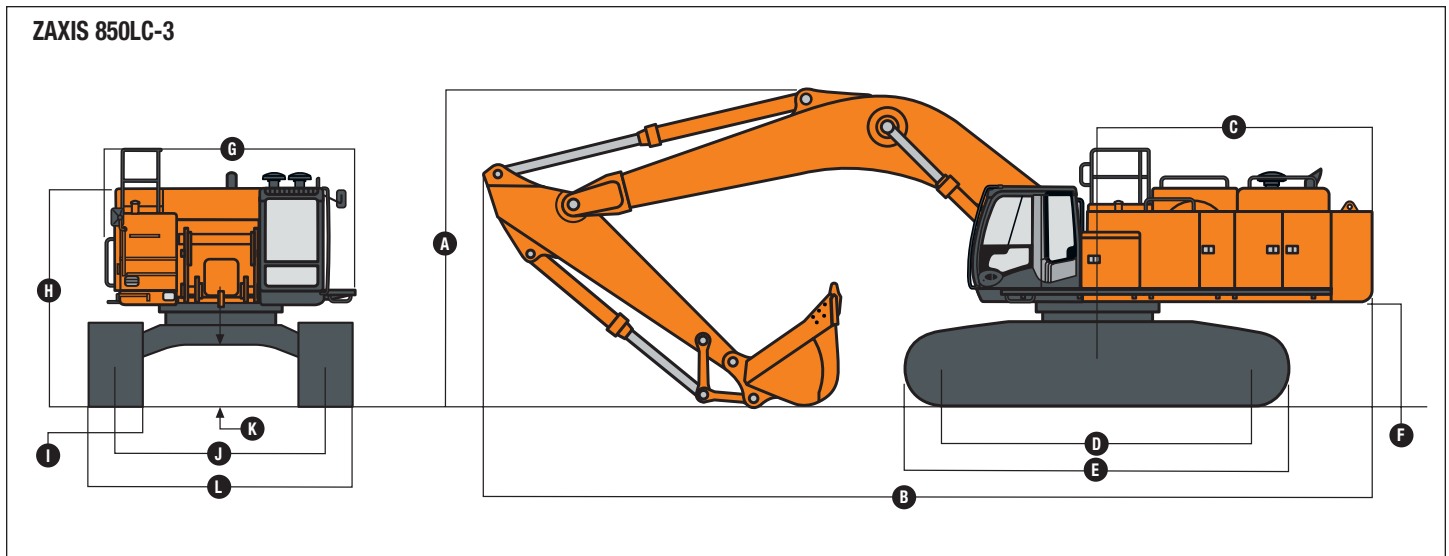

Packing Dimensions and Weights for Transportation

	Length	Height	Overall Width	Weight
Base Machine*	19 ft. 10 in. (6.04 m)	9 ft. 9 in. (2.96 m)	11 ft. 6 in. (3.50 m)	60,000 lb. (27 200 kg)
Side Frame**				
26-in. (650 mm) Shoe Width.....	20 ft. 10 in. (6.36 m)	4 ft. 11 in. (1.50 m)	4 ft. 3 in. (1.30 m)	26,700 lb. (12 100 kg)
30-in. (750 mm) Shoe Width.....	20 ft. 10 in. (6.36 m)	4 ft. 11 in. (1.50 m)	4 ft. 4 in. (1.33 m)	27,600 lb. (12 500 kg)
36-in. (900 mm) Shoe Width.....	20 ft. 10 in. (6.36 m)	4 ft. 11 in. (1.50 m)	4 ft. 8 in. (1.425 m)	28,418 lb. (12 890 kg)
40-in. (1020 mm) Shoe Width.....	20 ft. 10 in. (6.36 m)	4 ft. 11 in. (1.50 m)	4 ft. 10 in. (1.46 m)	29,366 lb. (13 320 kg)
Counterweight	11 ft. 0 in. (3.36 m)	5 ft. 4 in. (1.62 m)	28 in. (720 mm)	29,321 lb. (13 300 kg)
Boom				
23 ft. 4 in. (7.1 m).....	24 ft. 7 in. (7.49 m)	8 ft. 10 in. (2.70 m)	4 ft. 9 in. (1.45 m)	16,900 lb. (7670 kg)
27 ft. 7 in. (8.4 m).....	28 ft. 10 in. (8.78 m)	8 ft. 2 in. (2.50 m)	4 ft. 9 in. (1.45 m)	18,100 lb. (8200 kg)
32 ft. 10 in. (10.0 m).....	34 ft. 0 in. (10.37 m)	8 ft. 10 in. (2.70 m)	4 ft. 9 in. (1.45 m)	20,701 lb. (9390 kg)
Arm				
9 ft. 8 in. (2.95 m).....	14 ft. 8 in. (4.46 m)	5 ft. 5 in. (1.66 m)	34 in. (850 mm)	10,300 lb. (4650 kg)
12 ft. 2 in. (3.7 m).....	17 ft. 4 in. (5.29 m)	4 ft. 8 in. (1.42 m)	32 in. (820 mm)	9,500 lb. (4330 kg)
14 ft. 5 in. (4.4 m).....	19 ft. 4 in. (5.88 m)	4 ft. 8 in. (1.42 m)	32 in. (820 mm)	10,300 lb. (4660 kg)
17 ft. 9 in. (5.4 m).....	22 ft. 5 in. (6.83 m)	4 ft. 10 in. (1.48 m)	31 in. (800 mm)	10,913 lb. (4950 kg)
Less Counterweight and Arm	41 ft. 8 in. (12.70 m)	11 ft. 11 in. (3.63 m)	11 ft. 6 in. (3.50 m)	138,434 lb. (62 973 kg)

*Without front attachment; side frame; steps on the hydraulic oil tank side; and handrails on the right-hand frame, the fuel tank upper, and the lubricator upper.

**The dimensions and the weights indicate those of one side frame. The dimensions include the travel piping cover.

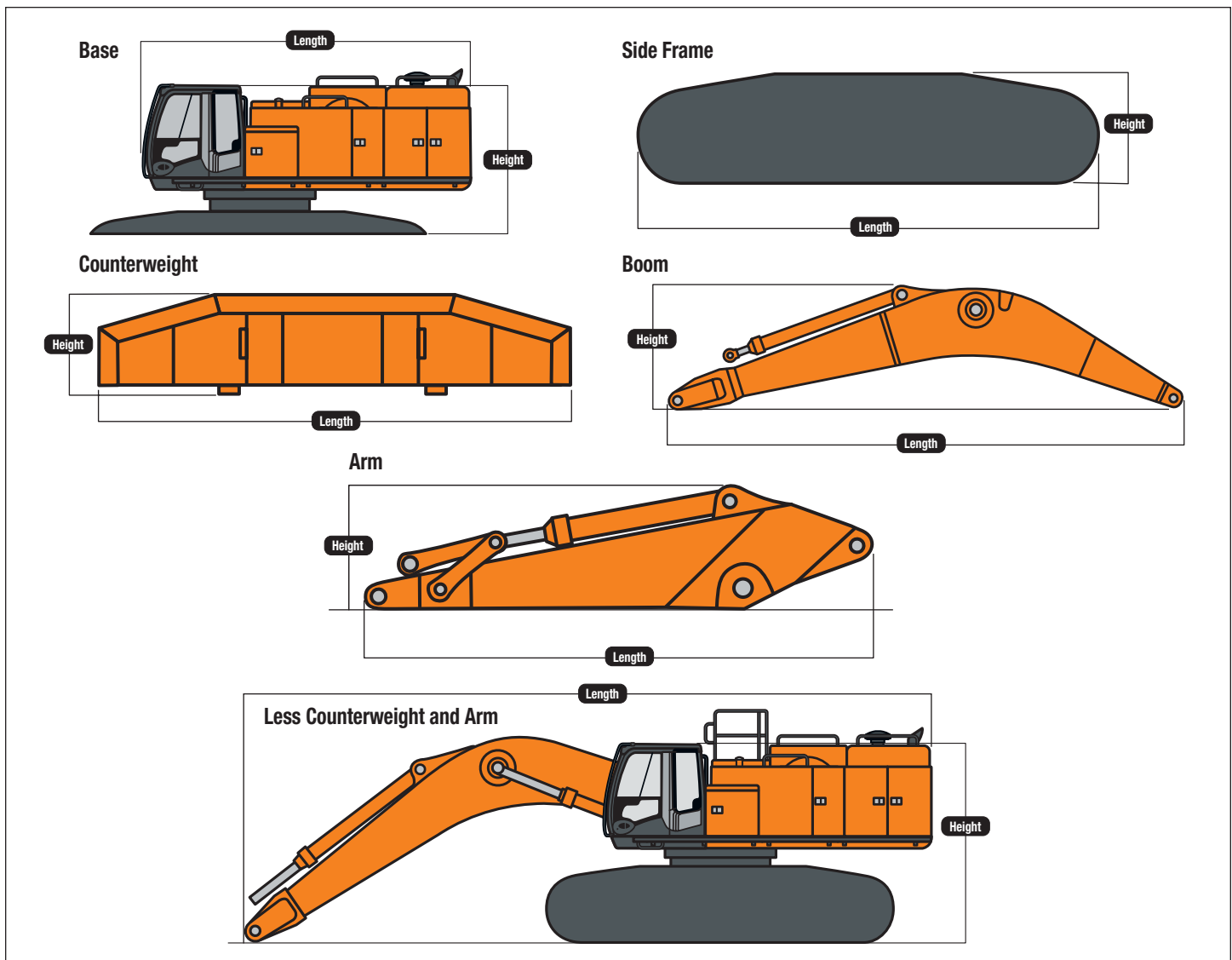

Equipment

Key ● Standard Equipment ▲ Optional or Special Equipment

Engine

- Certified to EPA Tier-3 emissions
- Auto-idle system
- Batteries (two 12 volt), 280-min. reserve capacity
- Coolant recovery tank
- Dual-element dry-type air filter
- Electronic engine control
- Enclosed fan guard (conforms to SAE J1308)
- Engine coolant to -34°F (-37°C)
- Fuel filter with water separator
- Full-flow oil filter
- Turbocharger with charge air cooler
- Muffler, under hood, with vertical curved end exhaust stack
- Cool-on-demand hydraulic-driven fan
- Glow-plug start aid
- 500-hour engine-oil-change interval
- 70% (35 deg.) off-level capability
- ▲ Engine-oil-sampling valve
- Hydraulic fan reverser

Hydraulic System

- Reduced-drift valve for boom down, arm in
- Auxiliary hydraulic valve section
- Spring-applied, hydraulically released automatic swing brake
- Auxiliary hydraulic-flow adjustments through monitor
- Auto power lift
- 4,000-hour hydraulic-oil-change interval
- ▲ Hydraulic-oil-sampling valve
- ▲ Auxiliary hydraulic lines
- ▲ Auxiliary pilot and electric controls
- ▲ Hydraulic filter restriction indicator kit
- ▲ Load-lowering control device
- ▲ Single-pedal propel control
- ▲ Pattern changer

Undercarriage

- Planetary drive with axial piston motors
- Propel motor shields
- Spring-applied, hydraulically released automatic propel brake
- Track guides, front idler and center
- Two-speed propel
- Upper carrier rollers (3)
- Sealed and lubricated track chain
- ▲ Double-bar grouser shoes, 26 in. (650 mm)
- ▲ Double-bar grouser shoes, 30 in. (750 mm)
- ▲ Double-bar grouser shoes, 36 in. (900 mm)
- ▲ Double-bar grouser shoes, 40 in. (1020 mm)

Upperstructure

- ▲ Counterweight-removal system
- Right- and left-hand mirrors
- Vandal locks with ignition key: Cab door / Fuel cap / Service doors / Toolbox
- Debris-screening side panel
- Service platform, left side
- Remote-mounted engine oil and fuel filters

Front Attachments

- Centralized lubrication system
- Dirt seals on all bucket pins
- Lubricator with hose reel and grease gun
- No-boom-arm option
- ▲ Boom, 27 ft. 7 in. (8.4 m)
- ▲ Boom, mass excavating, 23 ft. 4 in. (7.1 m)
- ▲ Boom, reach, 32 ft. 10 in. (10.0 m)
- ▲ Arm, mass excavating, 9 ft. 8 in. (2.95 m)
- ▲ Arm, 12 ft. 2 in. (3.7 m)
- ▲ Arm, 14 ft. 5 in. (4.4 m)
- ▲ Arm, 17 ft. 9 in. (5.4 m)
- ▲ Attachment quick-couplers
- ▲ Boom cylinder with plumbing to mainframe for no-boom-arm option
- ▲ Buckets: Ditching / Heavy duty / Heavy-duty high capacity / Severe-duty plate lip / Side cutters and teeth
- ▲ Buckets: General purpose / General-purpose high capacity / Severe-duty cast lip
- ▲ Material clamps
- ▲ Super-long fronts

Operator's Station

- Adjustable independent control positions (levers-to-seat, seat-to-pedals)
- AM/FM radio
- Auto climate control/air conditioner, 20,000 Btu/hr. (5.9 kW) with heater and pressurizer
- Built-in Operator's Manual storage compartment and manual
- Cell-phone power outlet, 12 volt, 60 watt, 5 amp
- Coat hook
- Deluxe air-suspension heated cloth seat with 4-in. (100 mm) adjustable armrests
- Floor mat
- Front windshield wiper with intermittent speeds
- Gauges (illuminated): Engine coolant / Fuel
- Horn, electric
- Hourmeter, electric
- Hydraulic shutoff lever, all controls

Operator's Station (continued)

- Hydraulic warm-up control
- Interior light
- Large cup holder
- Machine Information Center (MIC)
- Mode selectors (illuminated): Power modes – three / Travel modes – two / Work mode – one / Boom mode
- Multifunction, color LCD monitor with: Diagnostic capability / Multiple-language capabilities / Maintenance tracking / Clock / System monitoring with alarm features: Auto-idle, engine air cleaner restriction indicator light, engine check, engine coolant temperature indicator light with audible alarm, engine oil pressure indicator light with audible alarm, low-alternator-charge indicator light, low-fuel indicator light, fault code alert indicator, fuel-rate display, wiper-mode indicator, work-lights-on indicator, and work-mode indicator
- Fluid-level switch and indicator light for engine coolant and engine oil
- ▲ Monitor system with alarm features: Hydraulic oil filter restriction indicator light
- Motion alarm with cancel switch (conforms to SAE J994)
- Power-boost switch on right console lever
- Propel pedals and levers
- SAE two-lever control pattern
- Seat belt, 2 in. (51 mm), retractable
- ▲ Seat belt, 3 in. (76 mm), non-retractable
- Tinted glass
- Transparent tinted overhead hatch
- Hot/cold beverage compartment
- ▲ 24- to 12-volt D.C. radio convertors, 10 amp
- ▲ Circulation fan
- ▲ Protection screens for cab front, rear, and side
- ▲ Window vandal protection covers

Electrical

- 50-amp alternator
- Blade-type multi-fused circuits
- Positive terminal battery covers
- ▲ Cab extension wiring harness
- ZXLink™ Ultimate wireless communication system with 3 years of service

Lights

- Work lights: Halogen / One mounted on frame
- Work lights: Two mounted on boom / Two mounted on cab

Control Owning and Operating Costs

Customer Personal Service (CPS) is part of Hitachi's proactive, fix-before-fail strategy on machine maintenance that will help control costs, increase profits, and reduce stress. Included in this comprehensive lineup of ongoing programs and services are:

Fluid analysis program – tells you what's going on inside all of your machine's major components so you'll know if there's a problem before you see a decline in performance. Fluid analysis is included in most extended coverage and preventive-maintenance agreements.

Preventive Maintenance (PM) agreements – give you a fixed cost for maintaining a machine for a given period of time. They also help you avoid downtime by ensuring that critical maintenance work gets done right and on schedule. On-site preventive maintenance service performed where and when you need it helps protect you from the expense of catastrophic failures and lets you avoid waste-disposal hassles.

Extended coverage – gives you a fixed cost for machine repairs for a given period of time so you can effectively manage expenses. Whether you work in a severe-service setting, or you just want to spread the risk

of doing business, this is a great way to custom-fit coverage to your operation. An extended coverage contract also travels well because it's backed by the company and is honored by all Hitachi dealers.

Customer Support Advisors (CSAs) – the CSA program lends a personal quality to Customer Personal Service (CPS). Certified CSAs have the knowledge and skills for helping make important decisions on machine maintenance and repair. Their mission is to help you implement a plan that's right for your business and take the burden of machine maintenance off your shoulders.

Net engine power is with standard equipment including air cleaner, exhaust system, alternator, and cooling fan, at standard conditions per SAE J1349 and DIN 6270B, using No. 2-D fuel at 35 API gravity. No derating is required up to 10,000-ft. (3050 m) altitude. Gross power is without cooling fan.

Specifications and design subject to change without notice. Wherever applicable, specifications are in accordance with SAE standards. Except where otherwise noted, these specifications are based on a unit with 54-in. (1370 mm) bucket, 36-in. (900 mm) triple semi-grouser shoes, 29,321-lb. (13,300 kg) counterweight, full fuel tank, and 1,75-lb. (79 kg) operator.